



As greenhouse markets expand, growers constantly seek out ways to make their operations more efficient. An Ebb and Flood Irrigation system can help obtain greenhouse efficiency in a variety of crops by providing consistent and even watering with lower labour costs for irrigating as well clean-up.

Flooding and draining of the flood floors is done through underground piping and specially designed pneumatic valves. The quick opening and closing of the air-operated valves provide fast flooding and draining of the floors so there's no guess work on irrigation timing. Depending on the grower's preference, distribution of the water over the floors can be done by either formed gutters in the concrete floor or cored holes through the concrete into the distribution pipes.

The flood floor irrigation system gives a low maintenance design that can support any type of fertilizer injection system. Growers can maximize water and fertilizer use through recirculation and filtration while supplying fresh water as needed.

In addition to maximizing irrigation efficiency, maximum heating efficiency can be obtained by using floor heating in the concrete floors to get the heat where it's needed.



see over >

EBB & FLOOD FLOOR IRRIGATION

The components of an Ebb and Flood Irrigation system are very simple and therefore are very low maintenance. To the right is a schematic of the supply and drainage piping for a single bay of Flood Floor Irrigation. The drawing illustrates both a “cored hole” system and a “trench” system each having different growing features and design considerations.

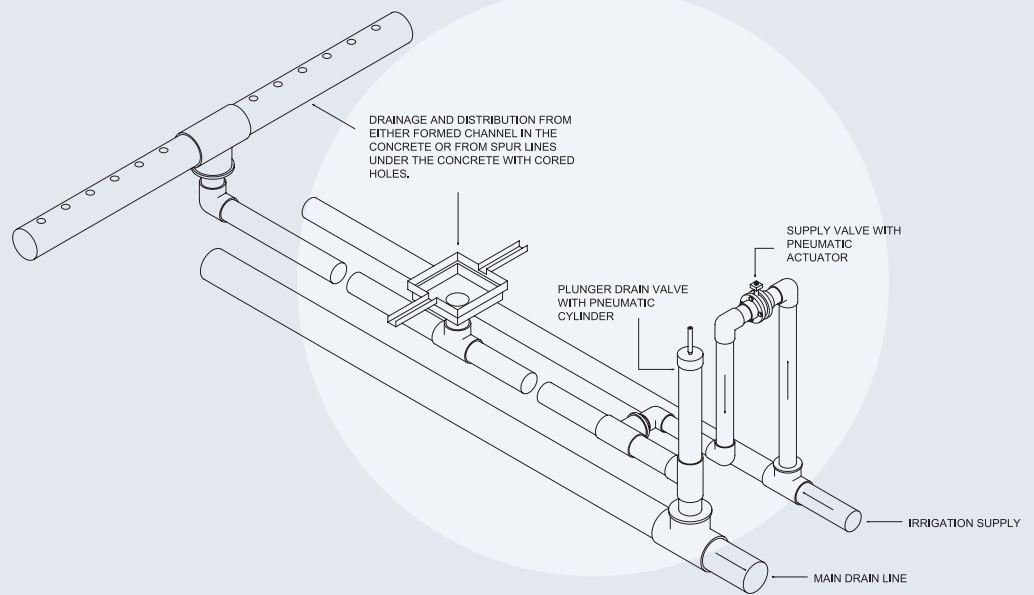

Because every greenhouse is unique and grower's demand vary, Prins Greenhouses will custom design each system to best suite your needs. As illustrated to the right, a gravity drain system from the filter can be utilized if the location is suitable. This design allows not only installation cost savings but also less maintenance with one less pump.

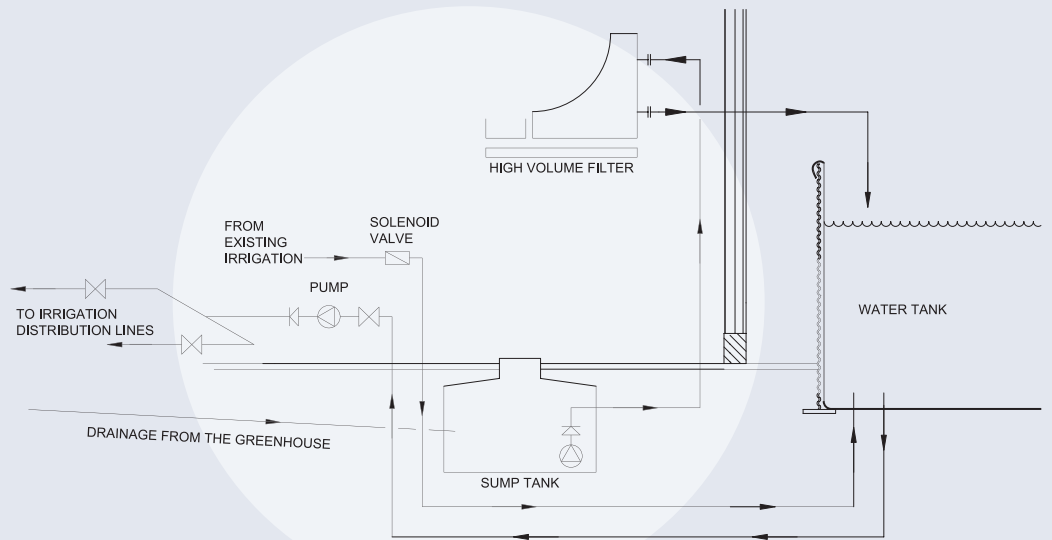

PRINS
Greenhouses

Construction • Systems • Supplies

38900 No. 4 Road
Abbotsford, British Columbia
Canada V3G 2G2
Tel: 604.852.4001 Fax: 604.852.4090
E-mail: admin@prinscanada.com